

# OM

## Operation Manual

### SCU/4 020V

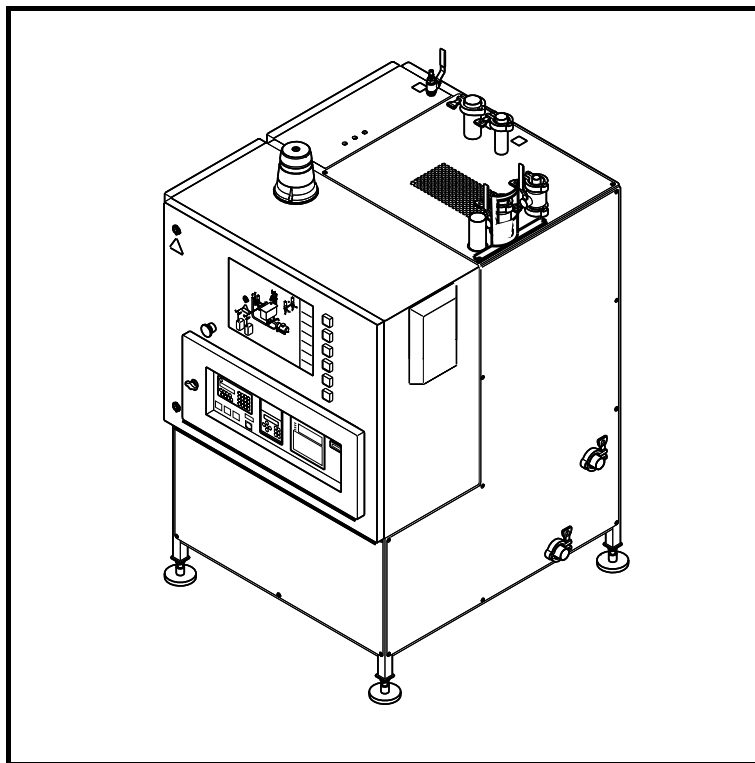

2.282448011fro.fm

 **Tetra Pak**

Doc No. OM-82448-0101

This document is valid for:

Series No/ Machine No

Sign.

# OM

## Operation Manual

### Separate Cleaning Unit 616054-020V

**Valid for machine series No.:**

22248

**Equipment included:**

927231-0100

Flowmeter

927232-0100

Recorder

927233-0100

Two-machine installation

1348485-0100

Three-machine installation

Doc No. OM-82448-0101

Issue 9809

Tetra Pak  
Tetra Brik Packaging Systems

<b>Introduction</b> . . . . .	<b>1</b>
<b>Safety precautions</b> . . . . .	<b>5</b>
<b>General description.</b> . . . . .	<b>21</b>
<b>Alarms /Troubleshooting</b> . . . . .	<b>27</b>
<b>Preparation</b> . . . . .	<b>33</b>
<b>Start</b> . . . . .	<b>41</b>
<b>Stop</b> . . . . .	<b>43</b>
<b>Weekly care</b> . . . . .	<b>45</b>
<b>Technical data</b> . . . . .	<b>51</b>

This page intentionally left blank

2.282448011TOC.fm

# Introduction

To ensure maximum safety, always read the section *Safety precautions* before doing any work on the equipment or making any adjustments.

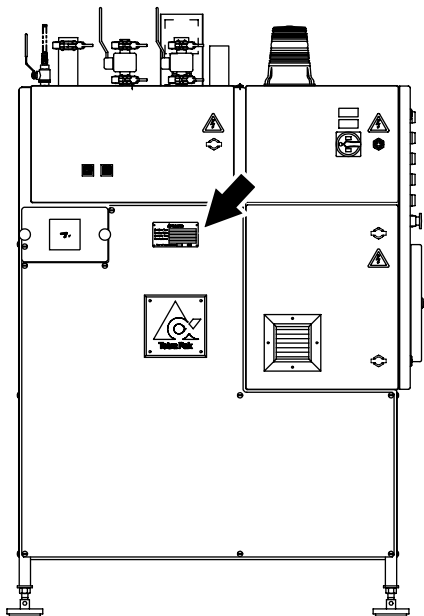

2.282448011int.fm

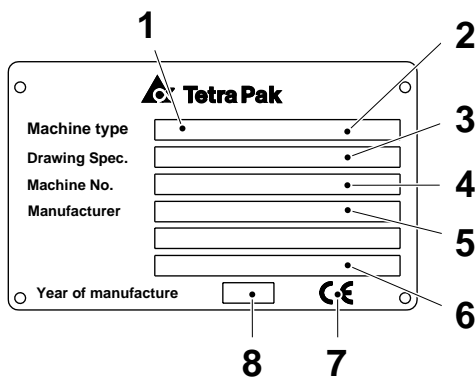

- 1 Machine type
- 2 Volume
- 3 Drawing specifications
- 4 Machine serial number
- 5 Manufacturer
- 6 (Designed by)
- 7 CE mark
- 8 Year of manufacture

## Equipment information

### Purpose

The purpose of this Tetra Pak equipment is to automate the cleaning of one, two, or three filling machines.

### Manufacturer

This Tetra Pak equipment has been manufactured by:

Tetra Brik Packaging Systems AB  
 Ruben Rausingsgata  
 221 86 LUND  
 Sweden

or by:

Tetra Brik Packaging Systems S.p.A.  
 Via Delfini 1  
 411 00 MODENA  
 Italy

### Service

Contact the nearest Tetra Pak service station.

### Identification

The figure shows an example of the equipment sign. The sign carries data needed when contacting Tetra Pak concerning this specific equipment.

### CE marking

This equipment complies with the basic health and safety regulations of the European Economic Area (EEA).

## Document information

### Purpose of Operation Manual (OM)

The purpose of the Operation Manual is to provide the operator with information on how to handle and operate the equipment before, during, and after production.

It is important to keep the manual for the life of the equipment and pass the manual on to any subsequent holder or user of the equipment.

### Design modifications

The directives in this document are in accordance with the design and construction of the equipment at the time it was delivered from the Tetra Pak production plant.

### Technical publications

The technical publications for this equipment are:

- Electrical Manual (EM)
- Installation Manual (IM)
- Maintenance Manual (MM)
- Operation Manual (OM)
- Spare Parts Catalogue (SPC)

Additional copies can be ordered from the nearest Tetra Pak service station.

When ordering technical publications, always quote the **document number** that can be found in the machine specification document.

**Number of pages**

This document contains a total of 54 pages.

**Copyright © 1998****Tetra Brik Packaging Systems**

All rights reserved. No parts of this document may be reproduced or copied in any form or by any means without written permission from Tetra Brik Packaging Systems.

This page intentionally left blank

2.282448011int.fm

---

# Safety precautions

To ensure maximum safety, always read this section carefully before doing any work on the equipment or making any adjustments.

---

## Hazard information

Hazard information in this document has the following significance:



Failure to observe information marked with "DANGER!" **puts your life in danger.**









Failure to observe information marked with "WARNING!" can result in **personal injury and/or serious damage to or destruction of equipment.**

### Caution!

Failure to observe information marked with "Caution" can result in **damage to equipment.**

## Mandatory signs

	<p>Wear eye protection</p> 
	<p>Wear hearing protection</p> 
	<p>Wear head protection</p> 
	<p>Disinfect hands/gloves</p>

2.282448011sp.fm

## Warning signs

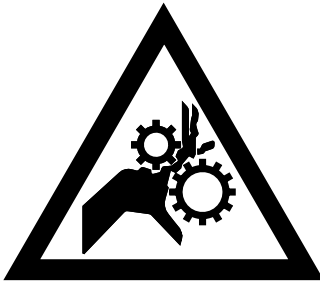

**Risk of entanglement!**



**Risk of corrosion and chemical burns!**

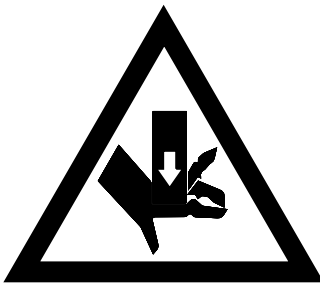

**Risk of crushing!**

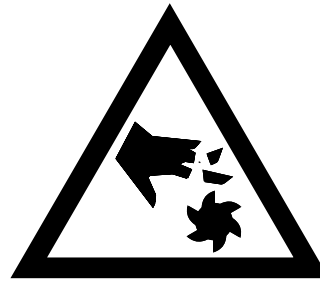

**Risk of cutting/amputation!**

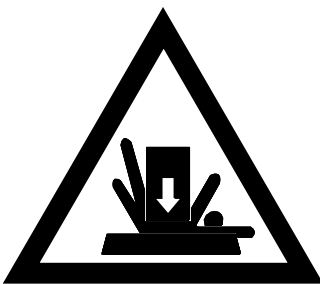

**Risk of crushing!**

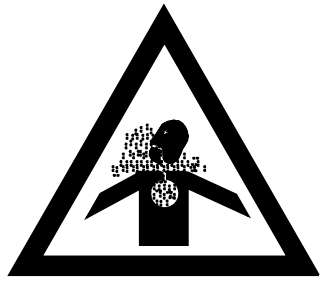

**Risk of intoxication!**

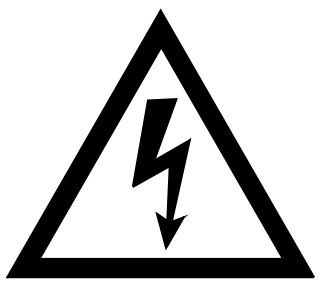

**Risk of electrocution!**



**Risk of falling!**

2.282448011sp.fm

*(cont'd)*

## Warning signs

**Risk of burns!**



**Risk of personal injury!**  
(general)



## Personnel

Only skilled or instructed persons are allowed to work on the equipment.

The manufacturer declines all responsibility for injury or damage if the instructions in this manual are not followed.

Personnel are responsible for:

- the equipment and the work area around the equipment
- all personnel in the vicinity of the equipment
- making sure that all safety devices are fully operational

Personnel must regard all electrical equipment as live. In general switch the equipment off at the mains power and padlock the switch before carrying out maintenance or repair work.

Electricians should be certified according to local regulations and have experience of similar types of installations, proven skills in reading and working from drawings and cable lists, and knowledge of local safety regulations regarding power and automation. Work with the electrical equipment must be performed only by skilled or instructed technicians.

According to EN 60204-1, 3.30 an instructed person is:

*An individual adequately advised or supervised by a skilled person to enable that individual to avoid hazards which electricity can create (e.g. operating and maintenance staff).*

According to EN 60204-1, 3.55 a skilled person is:

*An individual with technical knowledge or sufficient experience to enable that individual to avoid hazards which electricity can create.*



## General safety precautions

Wear hearing protection while the equipment is running.



## Electrical cabinet

There is high voltage in the electrical cabinet (up to 400 V). In case of accident, call for medical attention immediately.

Work inside the electrical cabinet must be performed by skilled or instructed persons only.

Electrical cabinet doors locked with screws may be opened only by skilled or instructed persons.

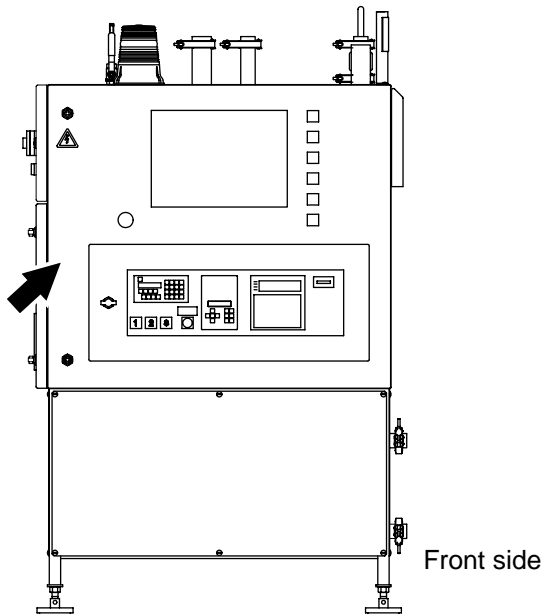
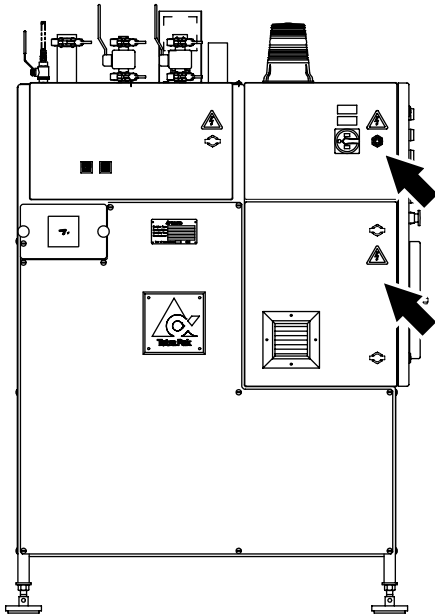

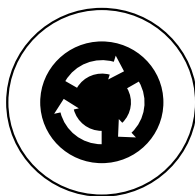

## Machine safety devices

### Emergency stop buttons

Learn the position of the **Emergency stop** buttons in order to stop the equipment immediately in case of danger to people or damage to the equipment.

The **Emergency stop** buttons do not switch off the power at the mains power switch.

Pushing the **Emergency stop** buttons will reset the equipment program to **Zero** position and deactivate all pneumatic cylinders.

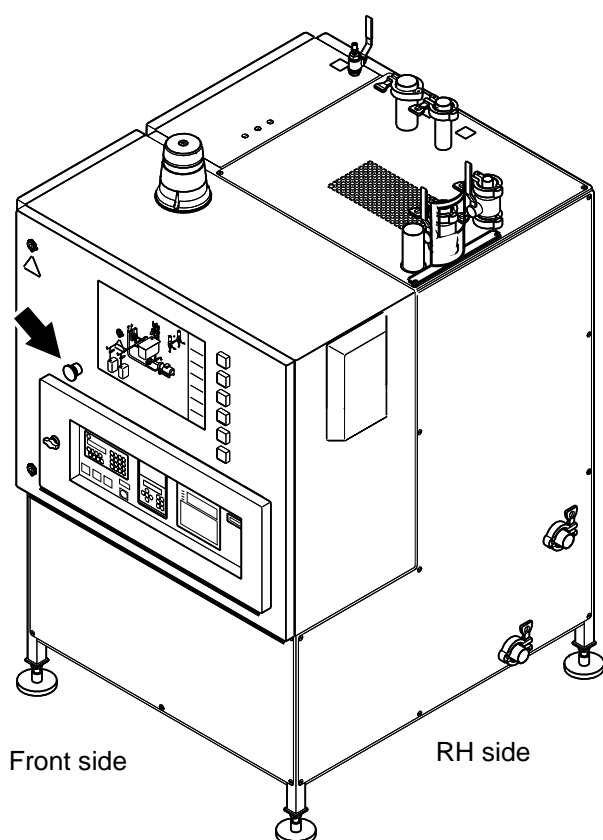

## Doors, covers and guards

Make sure that all doors, covers and guards are in place and functioning before operating the equipment.

Never remove covers or guards while the equipment is operating.

Some equipment parts protected by doors, covers, and guards may be hot.

In case of accident, call for medical attention.



**WARNING!**

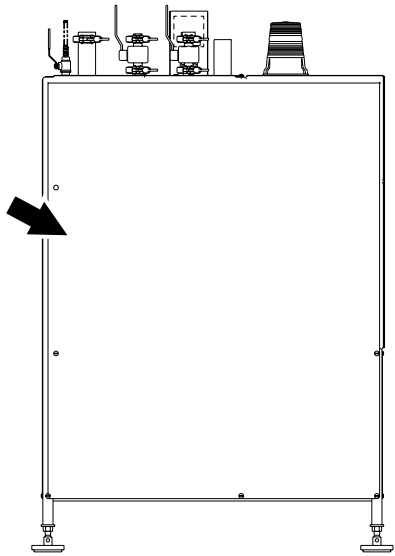

Rear side

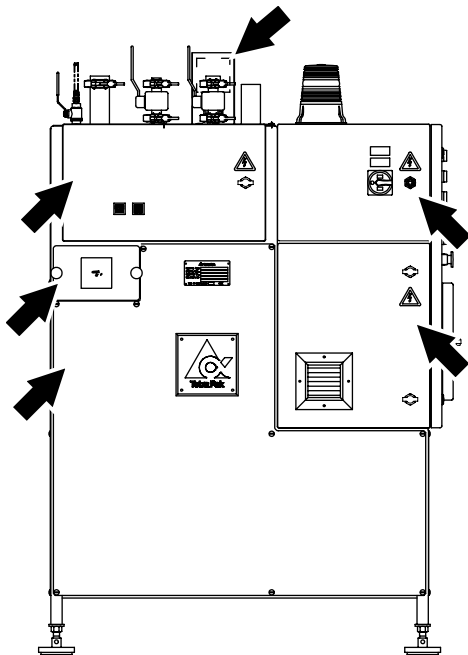

LH side

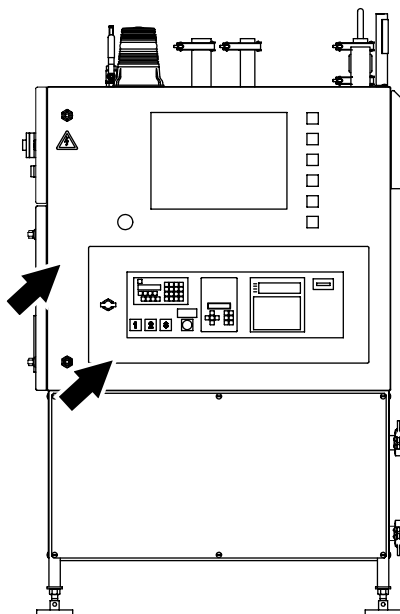

Front side



## Chemical products

### Risk of personal injury!

Certain chemical products are toxic and/or inflammable. Carefully follow the instructions on the container label.

Follow the supplier's instructions for handling and disposal of the chemical products.

---

## Personal protective equipment

- **Safety goggles**, TP No. 779130-102
- **Apron**, TP No. 90303-5
- **Shoes** made of PVC, PE plastic or rubber
- **Protective gloves** made of neoprene, TP No. 90303-4

Before starting work with any chemical products, make sure that:

- the showers work
- a portable, TP No. 90303-6, or wall-mounted eyewash device is available at or near each machine site
- there are additional washing facilities



## General emergency procedures

If you accidentally **swallow** chemical products, drink large amounts of lukewarm water.

If you get splashes or vapour from chemical products in your **eyes**, wash your eyes thoroughly with lukewarm water for 15 minutes (keeping eyelids wide apart).

If chemical products comes into contact with **skin** or **clothes**:

- rinse immediately with plenty of water
- if skin burns appear, call for medical attention immediately
- thoroughly wash clothes before wearing them again

If you experience irritation or pain due to having **inhaled** chemical products vapour:

- leave the affected area and get some fresh air
- if the symptoms get worse, call for medical attention



## Caustic soda

### Risk of personal injury!

Slow corrosive action. May be harmful if inhaled. Can cause shortness of breath. Caustic soda may cause irritation or damage if it comes in contact with skin and eyes.



### Handling of caustic soda

- Never mix caustic soda with nitric acid!
- Make sure that the areas used for handling of caustic soda are well ventilated.
- If caustic soda is spilt on the floor, soak it up with sand, turf dust or other suitable absorbent. Dispose of the absorbent appropriately.
- Rinse the floor with water afterwards.



### Caustic soda container

The container should be kept closed.



## Nitric acid

### Risk of personal injury!

Quick corrosive action. Very harmful if inhaled. The fumes of nitric acid can cause serious damage to the lungs. Nitric acid may cause burns if it comes into contact with skin and eyes.



### Handling of nitric acid

- Never mix nitric acid with caustic soda!
- Before starting any work with nitric acid, make sure that respiratory equipment is on hand for emergency situations.
- Make sure that the areas used for handling of nitric acid are well ventilated.
- If nitric acid is spilt on the floor, soak it up with sand, turf dust or other suitable absorbent. Dispose of the absorbent appropriately.
- Rinse the floor with water afterwards.



### Nitric acid container

- The container should be kept closed.
- To prevent damage to the lungs, it is advisable to put on a gas mask with a filter suitable for fumes produced by nitric acid before opening the container.
- When moving the container ensure that the valves are closed and that the protection nuts and safety caps are securely fastened.
- Follow the supplier's instructions and the local regulations for disposing of the empty containers.



**WARNING!**

## Hot parts

### Risk of personal injury!

The steam connection (1), the outlet solution connection (2), the inlet solution connection (3), and the discharge pipes (4) reach temperatures above 60° C. Use a pair of protective gloves to prevent burns.

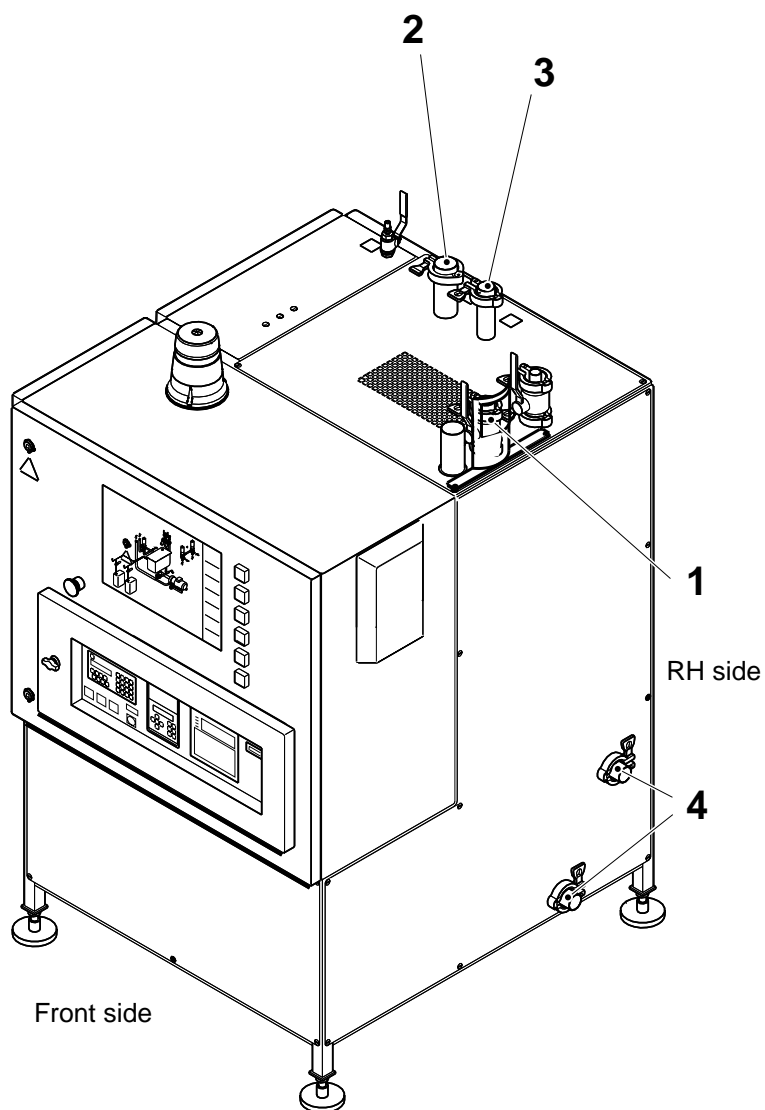

- 1 Steam connection
- 2 Outlet solution connection
- 3 Inlet solution connection
- 4 Discharge pipes



## Equipment for lifting and moving loads

Make sure that the capacity of the lifting equipment is adequate and that the equipment itself is in good working order.

If lifting tackle has to be joined to make up the necessary lengths, make sure that the joins are secure and have the same lifting capacity as the rest of the tackle.

Always engage the safety clip on lifting hooks to prevent the tackle from slipping off.

Use ropes or poles to steady and manoeuvre loads. Do **not** use hands or feet.

Make sure that the route and the destination are free from obstacles before moving a suspended load. It must be possible to lower the load to the floor quickly and safely in an emergency.

When depositing loads, keep the lifting equipment in place until the stability of the load has been checked.

This page intentionally left blank

2.282448011sp.fm

# General description

## Caution!

To ensure maximum safety, always read this section and the *Safety precautions* carefully before doing any work on the equipment or making any adjustments.

**This section describes the main parts of the machine and the terminology.**

---

## Abbreviations

	Description
CIP	Cleaning In Place
LH	Left Hand
OE	Optional Equipment
OM	Operation Manual
RH	Right Hand
SCU	Separate Cleaning Unit

2.2TB04448en.fm

## LH side

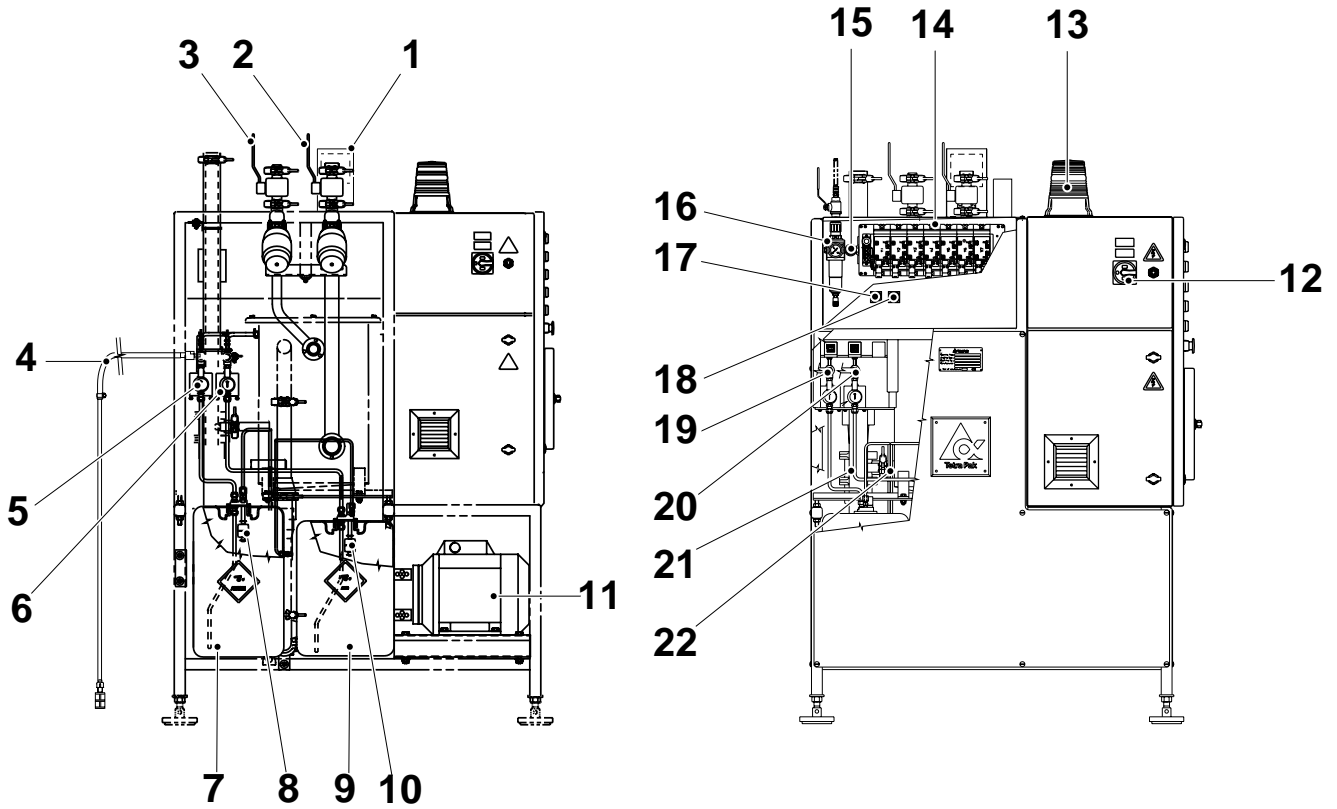

- |    |                          |    |                               |
|----|--------------------------|----|-------------------------------|
| 1  | Steam valve cover        | 15 | Pressure switch               |
| 2  | Steam valve              | 16 | Air regulator                 |
| 3  | Water valve              | 17 | Alkali autoloader push-button |
| 4  | External autoloader pipe | 18 | Acid autoloader push-button   |
| 5  | Alkali pump              | 19 | Alkali autoloader connection  |
| 6  | Acid pump                | 20 | Acid autoloader connection    |
| 7  | Alkali tank              | 21 | Alkali safety pipeline        |
| 8  | Alkali level probe       | 22 | Acid safety pipeline          |
| 9  | Acid tank                |    |                               |
| 10 | Acid level probe         |    |                               |
| 11 | Pump                     |    |                               |
| 12 | Main switch              |    |                               |
| 13 | Beacon                   |    |                               |
| 14 | On/Off valve panel       |    |                               |

## Open rear side

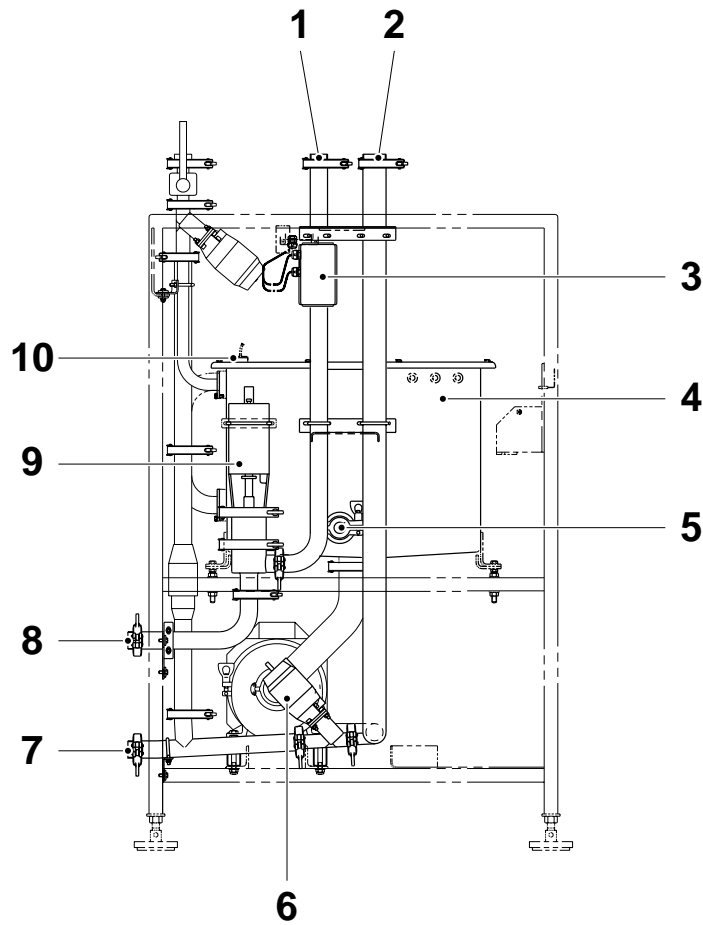

2.2TB04448en.fm

- |                        |                             |
|------------------------|-----------------------------|
| 1 Solution inlet       | 7 Gravity discharge circuit |
| 2 Solution outlet      | 8 Pump discharge circuit    |
| 3 Flowmeter (optional) | 9 Change over valve         |
| 4 Tank                 | 10 Level probe              |
| 5 Conductivity probe   |                             |
| 6 Discharge valve      |                             |

## Front panel

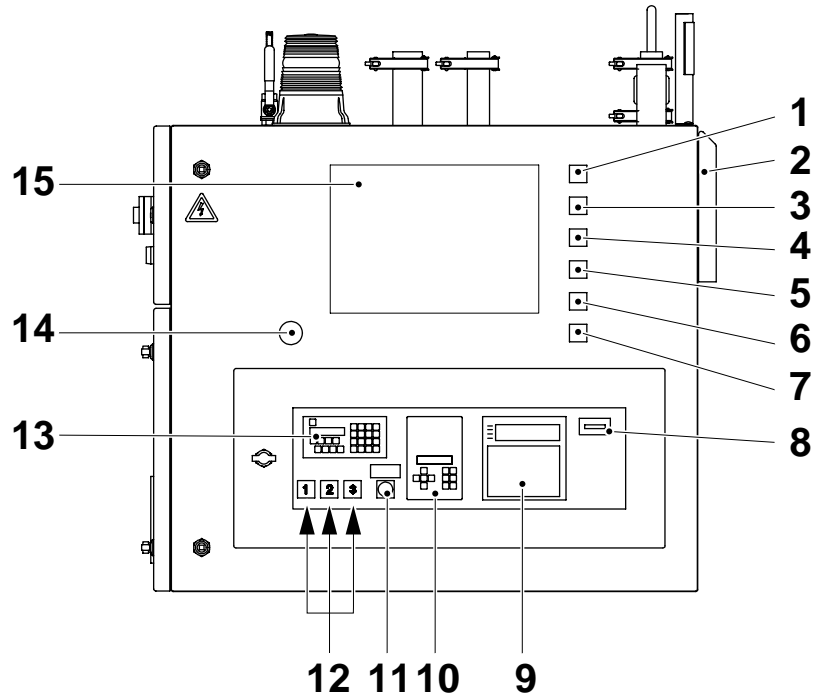

- |                            |                                      |
|----------------------------|--------------------------------------|
| 1 Selector key             | 10 Conductivity meter                |
| 2 Cooling fan              | 11 Selector switch, cleaning         |
| 3 Lamp test push-button    | 12 Selector buttons, filling machine |
| 4 Alarm reset push-button  | 13 Flowmeter display                 |
| 5 Stand-by push-button     | 14 Emergency stop button             |
| 6 Program up push-button   | 15 Monitor panel                     |
| 7 Program down push-button |                                      |
| 8 Counter                  |                                      |
| 9 Recorder                 |                                      |

## Control panel

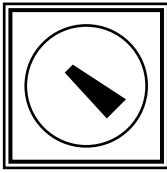

1

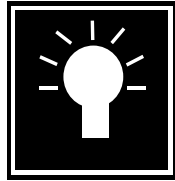

2

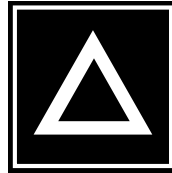

3

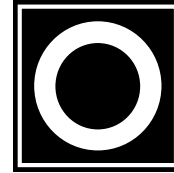

4

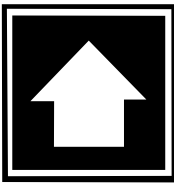

5

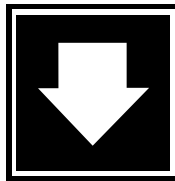

6

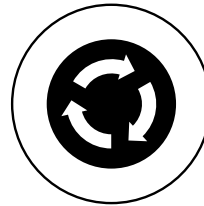

7

2..2TB04448en.fm

- 1 Selector key
- 2 Lamp test button
- 3 Alarm reset button
- 4 Stand-by button

- 5 Program up button
- 6 Program down button
- 7 Emergency stop button

## Machine display with program step

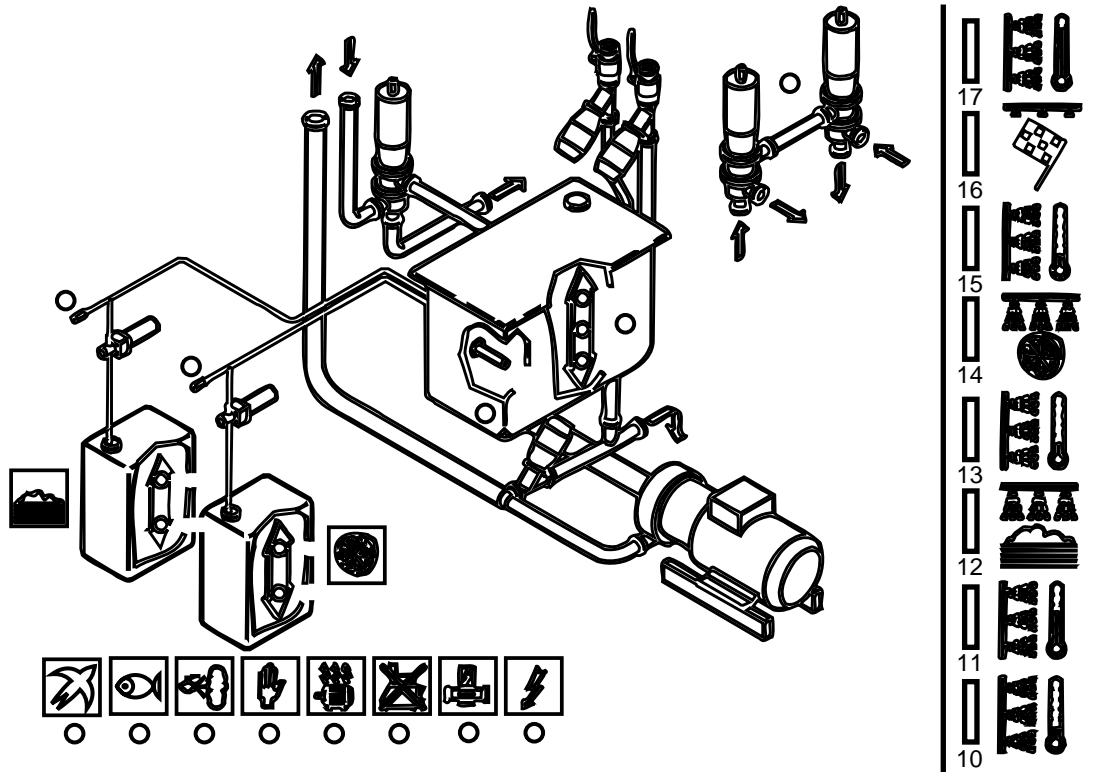

- 10 Pre-rinsing
- 11 Warm rinsing
- 12 Alkali cleaning
- 13 Alkali rinsing
- 14 Acid cleaning
- 15 Acid rinsing

- 16 Selected cleaning completed
- 17 Disinfection rinsing (optional)

Step 17 is activated by the **Selector key** on the front panel.

# Alarms /Troubleshooting

This section describes the alarms (troubleshooting).

2.2TB05448en.fm

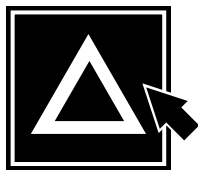
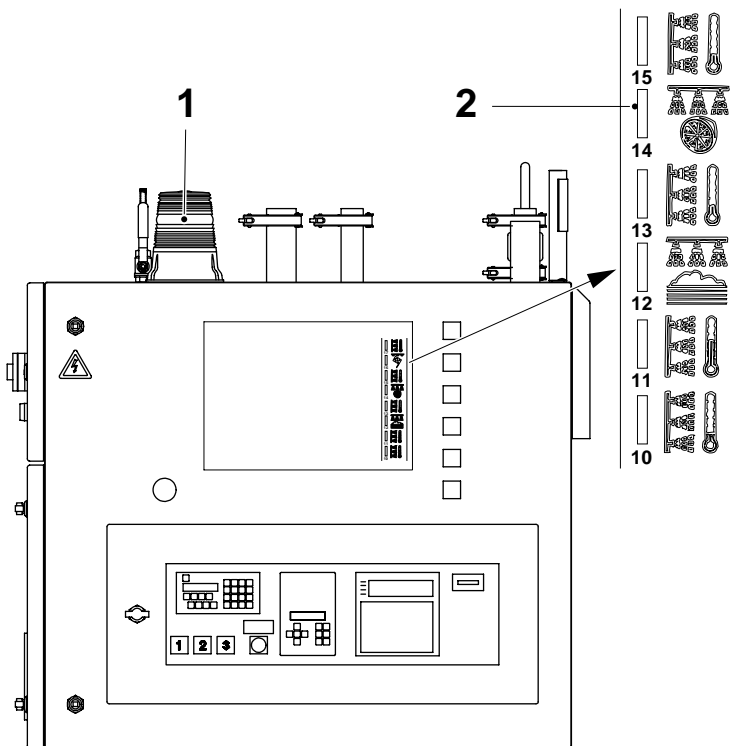

## 1

If some form of action is required, the beacon (1) starts flashing. Also sometimes the machine stops.

On the monitor panel, the rectangle (2) near the current cleaning step lights up with a fixed light.

When the appropriate action is taken some LEDs stop flashing while others go out.

Press the **Alarm reset** button.

### Note!

In case of alarm No 25 or No 27:

-Do not change anything on the machine.

The machine must remain in the same condition as it was prior to the alarm.

-Press the **Alarm reset** button for at least 5 seconds.

## 2

After the **Program up** button begins to flash, press it.

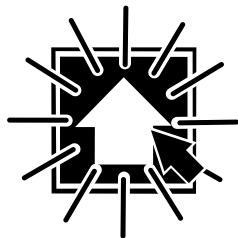

## Monitor panel

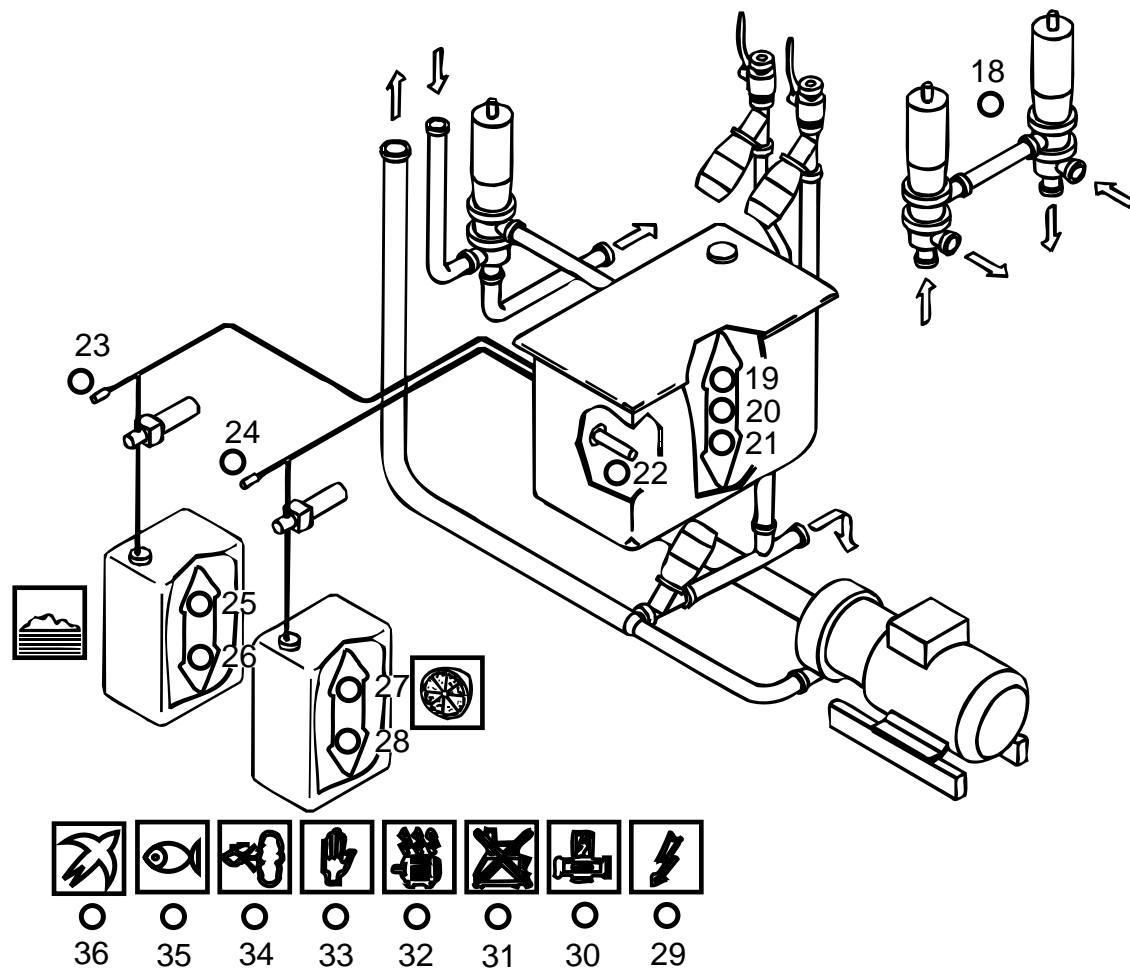

2.2TB05448en.fm

Pos	Alarm	Cause	Machine action	Instruction to operator
18	Change-over valve	Wrong position	Stand-by	Call technician
19	Main tank 1	High level not reached	Stand-by	Check water inlet pressure tap. Call technician
20	Main tank 2	Intermediate level not reached	Stand-by	Check water inlet pressure tap. Call technician
21	Main tank 3	Low level not reached	Stand-by	Check solution outlet line. Call a technician
22	Incorrect conductivity value	Incorrect conductivity value on instrument	Stand-by	Check the alkali/acid level in the tanks. Call technician
23	Alkali autoloading connection	Wrong position	Stand-by	Check if autoloading plug is in. Call technician
24	Acid autoloading connections	Wrong position	Stand-by	Check if autoloading plug is in. Call technician
25	Alkali autoloading time too long or float malfunction	Autoloading circuit defective	Stand-by	Check the external tank level In case of failure of concentrated circuit call a technician
26	Alkali tank empty	Low alkali level	Alarm	Fill the tank
27	Acid autoloading time too long or float malfunction	Autoloading circuit defective	Stand-by	Check the external tank level In case of failure of concentrated circuit call a technician
28	Acid tank empty	Low acid level	Alarm	Fill the tank
29	Surge filter activated	Low voltage	Alarm	Call technician
30	Cleaning flow	Low cleaning flow	Stand-by	Check for leakages or obstructions, then call technician
31	Selected filler(s) not ready for CIP	No signal from machine	Stand-by	Check selector position. Call technician
32	Cleaning pump overload	Motor overloaded	Stand-by	Call technician
33	Emergency stop push button	Button activated	Reset to <b>Zero</b> position	Remove cause and check emergency stop button position

## Monitor panel

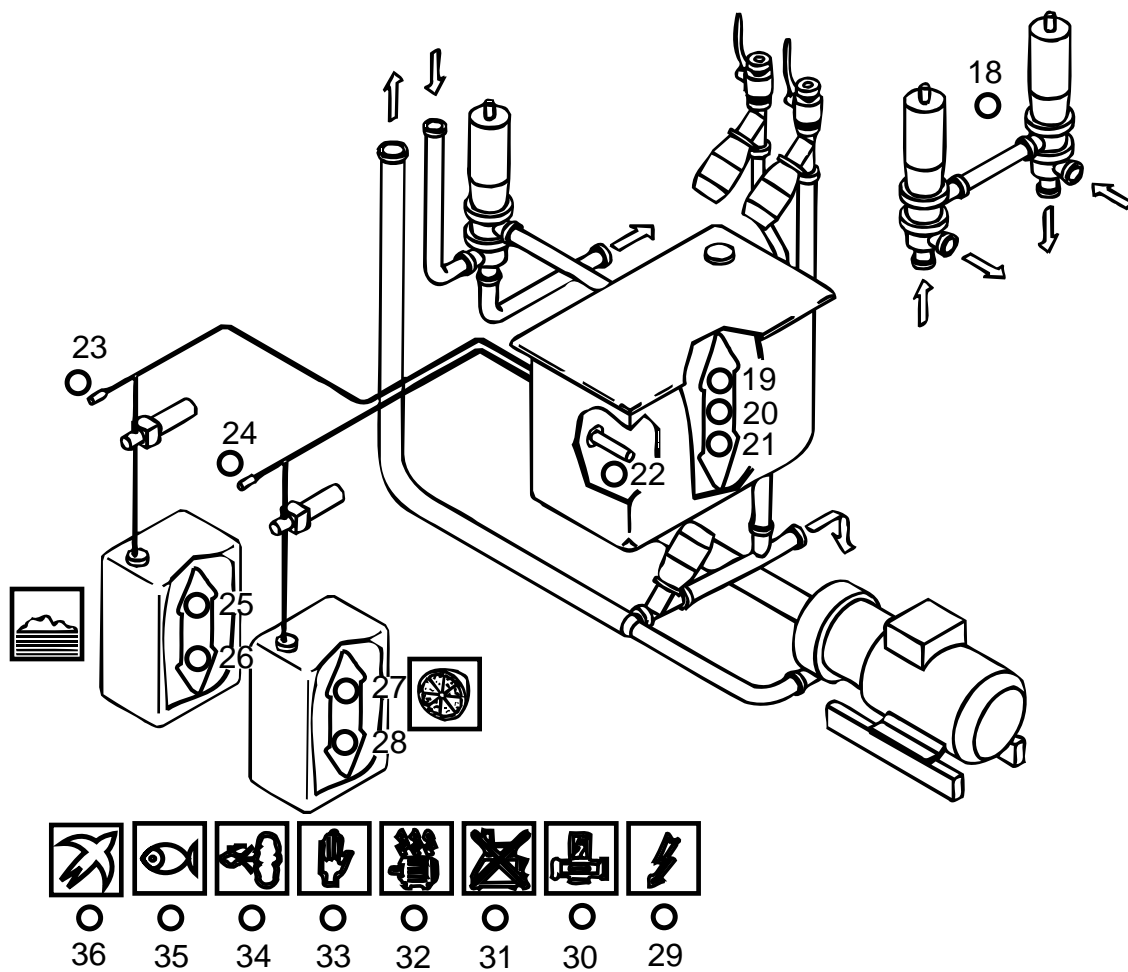

2.2TB05448en.fm

<b>Pos</b>	<b>Alarm</b>	<b>Cause</b>	<b>Machine action</b>	<b>Instruction to operator</b>
34	Steam supply	Heating time too long	Stand by	Check that the steam tap is open
35	Water supply	Water filling time too long	Stand by	Check that the water tap is open
36	Air supply	Low air pressure	Stand by	Check that the air tap is open

This page intentionally left blank

# Preparation

## Caution!

Execute all steps in the right order as listed in the instructions to prevent personal injury.

This section describes how to prepare the machine before starting the cleaning process.

## 1

Connect the filling machine(s) for cleaning.

See the instructions in the OM of the filling machine concerned.

Check that the pressure, return and drain connections have been tightened.

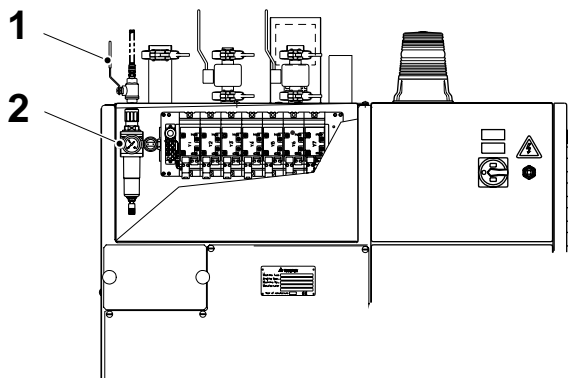

## 2

Open the air supply tap (1) and check the air pressure (2) on the gauge in the pneumatic cabinet.

Set to 0.6 - 0.7 MPa.

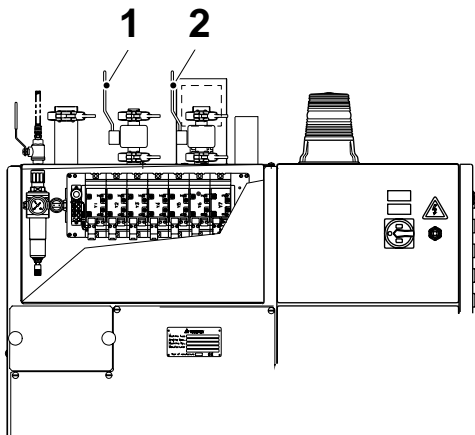

## 3

Open the water (1) and steam (2) valves.

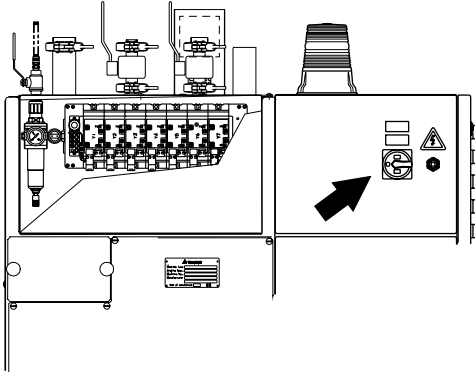

**4**

Turn the main switch **on**.

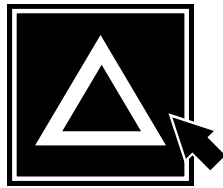

**5**

Press **Alarm reset**.

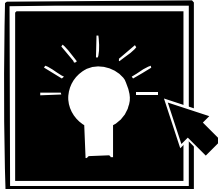

Press **Lamp test** and check that all signal lamps light up.

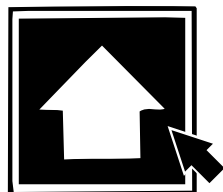

**6**

Press **Program up**.

The machine program is in **Setting** position.

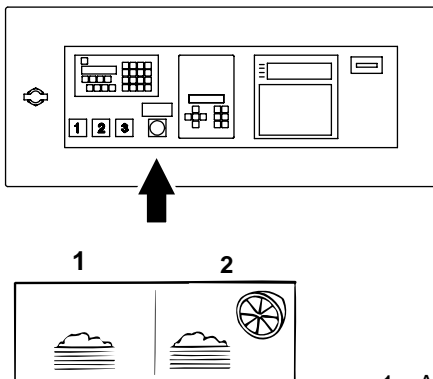

**7**

Select **Daily cleaning** (only alkali) or **Weekly cleaning** (alkali and acid) using the selector switch.

- 1 Alkali cleaning
- 2 Alkali-Acid cleaning

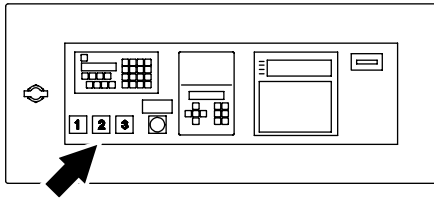

## 8

Select the filling machine(s) to clean using the selector buttons. The button light turns on for each machine selected.

## 9

### Recorder

Check there is enough paper in the recorder for at least one cleaning cycle.

If not, load paper as follows.

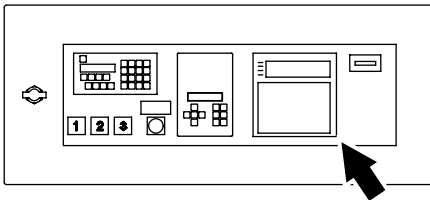

## 10

Fan and loosen the recording paper so as to prevent overlapping feed.

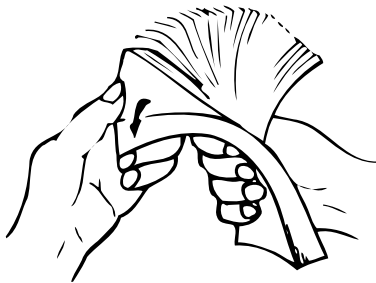

## 11

Open the front door, hold the drawout lever on the paper feed unit and pull it forward. Then the paper feed unit will be drawn out.

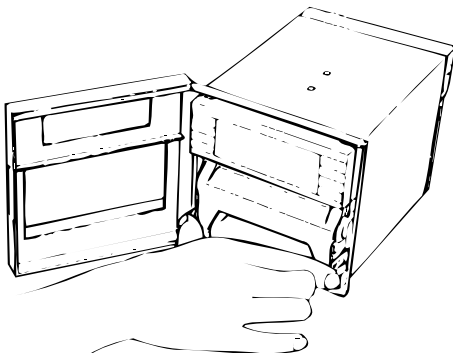

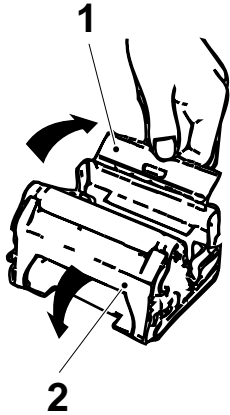

## 12

Hold the chart paper retainer (1) and open it backward.

Hold the chart paper retainer (2) and move it forward.

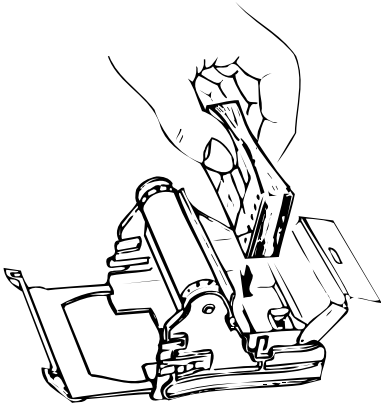

## 13

Insert chart paper into the compartment.

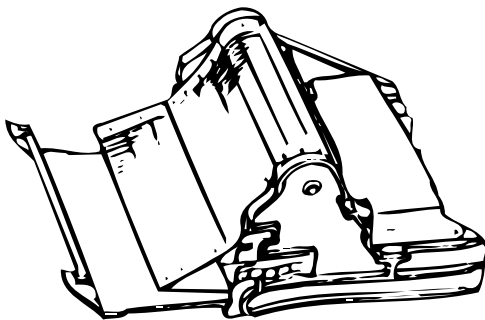

## 14

Pull out the first or second fold of the chart paper, then close the compartment.

Make sure that the sprocket is engaged correctly in the perforations of the chart paper.

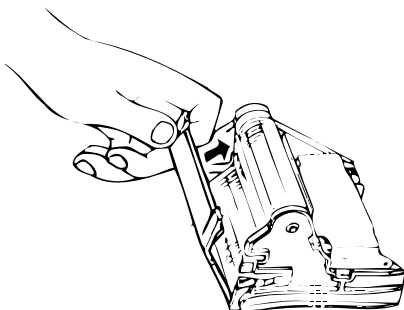

## 15

Pull out the first or second fold of the chart paper, then close the compartment.

Make sure that the sprocket is engaged correctly in the perforations of the chart paper.

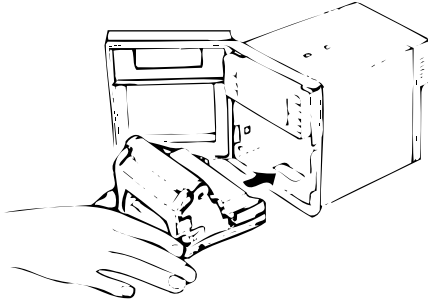

## 16

Mount the paper feed unit in the recorder.  
Check that it is properly locked in position

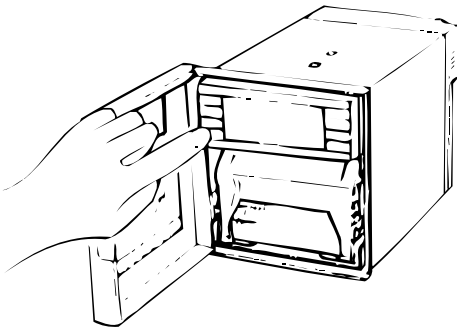

## 17

Push the **Feed** key and check that the chart paper is fed out smoothly.

If not, go through the procedure from step 8 again.

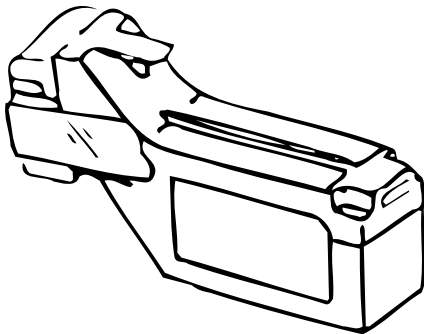

## 18

Set the recording head ready by taking it out of its aluminium pack.

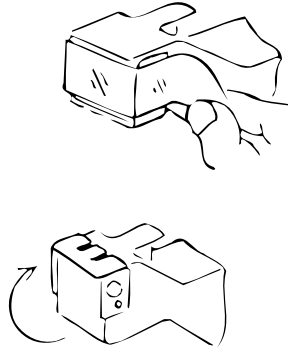

## 19

Tear the tape.

Open the cap by turning it in the direction indicated by the arrow. (If the head is not going to be used for a long time, close the cap back in its original position). The cap is integral with the head unit. Turn it about 180° until it stops against the top of the head.

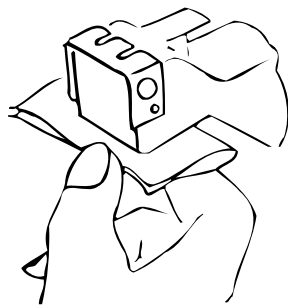

## 20

Lightly press the nozzle surface (the surface from which ink is discharged) with a piece of cloth.

Make sure that the cloth is properly impregnated with the 4 colours: blue, red, yellow and black.

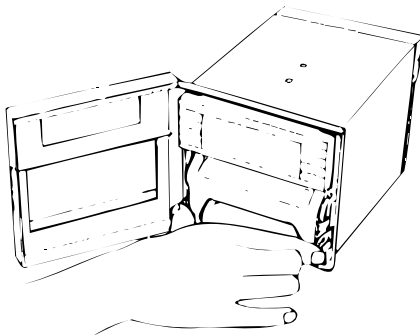

## 21

Make sure the recorder is in stop position.

Press the **Record** key.

Open the front door, hold the drawout lever on the paper feed unit and pull it forward.

The paper feed unit will be drawn out.

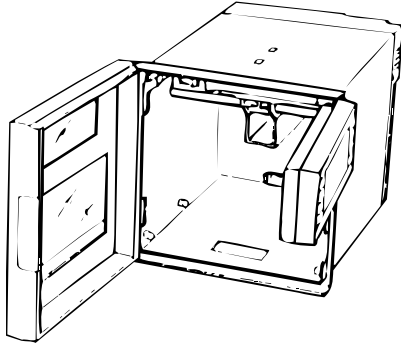

## 22

Hold the left end of the indicator and pull it forward.

The indicator will turn 90°.

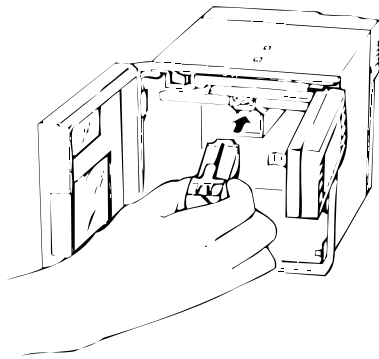

## 23

Hold the recording head horizontal, line it up with the carriage in the main unit. Slide it in slowly and press it fully in.

Take care not to touch the nozzle surface of the head.

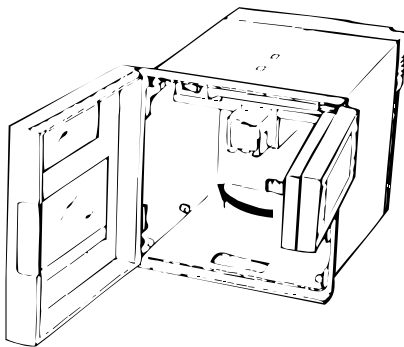

## 24

Set the indicator in its original position.

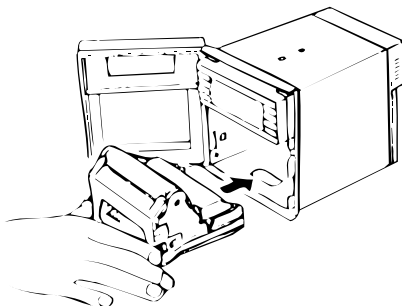

## 25

Set the paper feed unit in its original position.

Close the front door.



## 26

### Risk of personal injury!

Wear safety goggles, protective gloves, and gas mask when handling alkali and/or acid.

To prevent injury to people near the equipment and/or damage the equipment, make sure chemical products do not leak:

- When moving a container, ensure that the valves are closed and that the protection nuts and safety caps are securely fastened.
- Always check the label on the container before attaching the filling tube to the machine.
- Stay near the machine while the tanks are being filled.

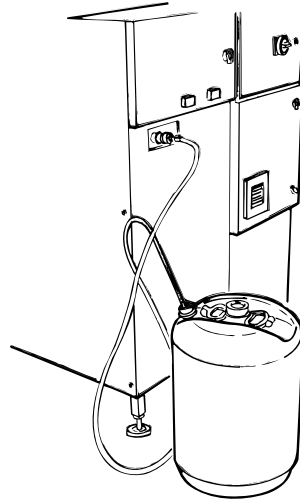
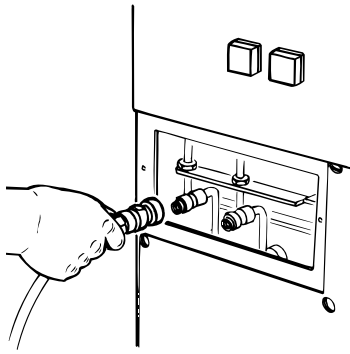

If the **Low level alkali/acid** alarm comes on, it is necessary to fill the tanks.

Before connecting the filling tube to the connector, clean the connector with a sponge.

To start filling, press the button for the product being filled (alkali or acid).

2.2TB06448en.fm

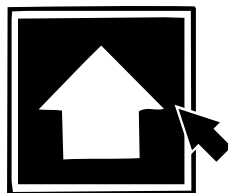

## 27

### Flowmeter

Press **Program up**.

Open the front panel and push **Flow** on the flowmeter display.

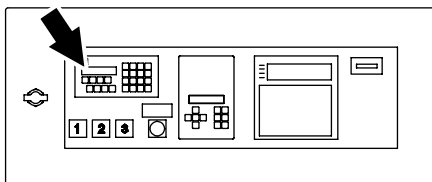

---

# Start

---

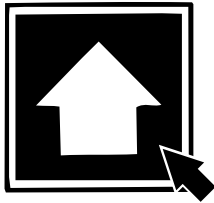

## 1

Press **Program up**.

Check for any leaks on the circuit.

### **Note!**

If a machine that is selected is not ready for CIP (alarm 31), press the button for the machine(s). The button light turns off. Cleaning continues for the remaining machines that have been selected.

It is necessary to wait for the cleaning cycle to complete before selecting the other machine(s) to clean.

This page intentionally left blank

2.2TB08448en.fm

# Stop

This section describes how to stop the machine in:

- Normal stop
- Standby
- Emergency stop

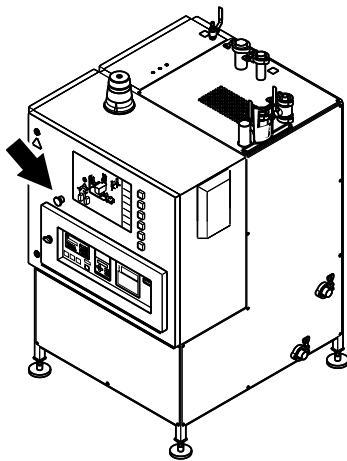

## 2

### Emergency stop

Every time you push the button the program steps to **Zero** position (only for safety reasons), the cleaning cycle restarts from the beginning.

### Normal stop

When cleaning is finished, press **Program Down** for at least three seconds.

The program steps to **Zero** position.

Drain the concentrated circuit pipeline. See the *Weekly care* section.

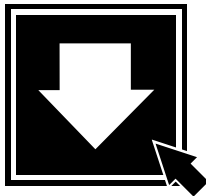

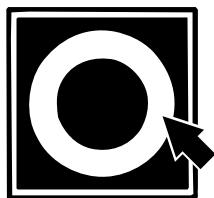

## Standby

1

Press the stand-by button to stop the program and restart from the same step.

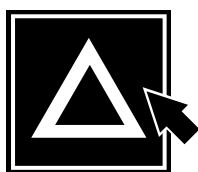

2

To restart, press **Alarm Reset** and **Program Up**.

### Note!

If you press **Program down** for more than three seconds, the program steps to **Zero** position.

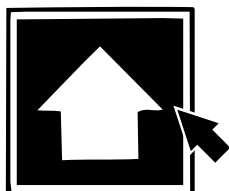



### Chemical products!

The chemical products in the concentrated circuit pipeline can cause chemical burns and, if inhaled, can cause shortness of breath. Use protective equipment.

## Weekly care

Carry out *Weekly care* after the cleaning process has finished and before doing any maintenance operation.

### 1

Turn the main switch **Off**.

### 2

Remove the panel (1) on the LH side of the machine.

Remove the autoload connection cover (2).

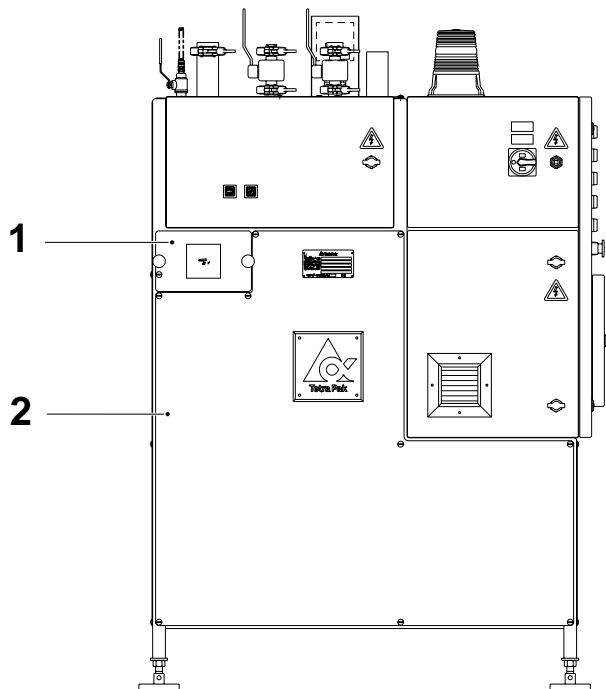

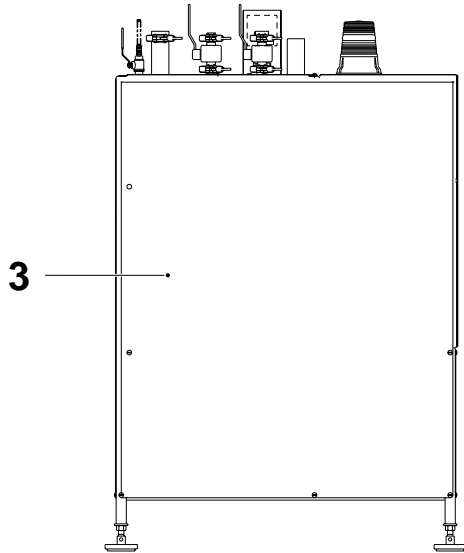

### 3

Remove the rear panel (3) of the machine.

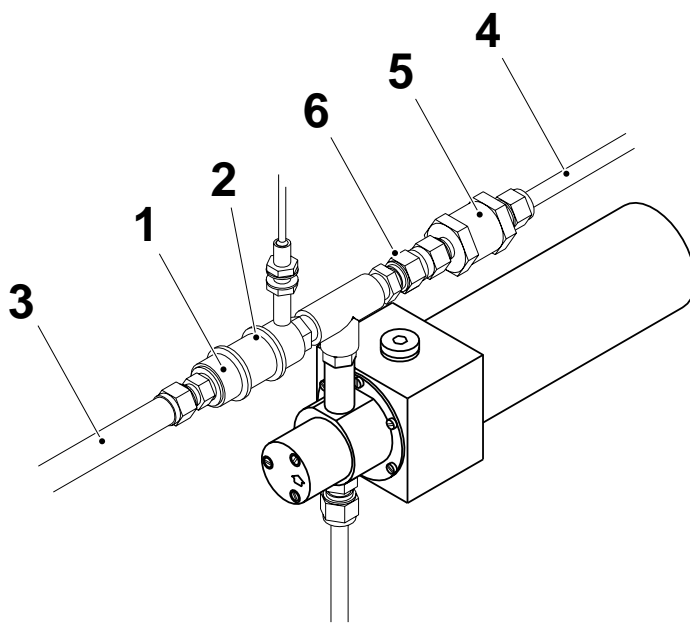

### 4

Connect the quick release coupling (1) of the Safety kit TP No 929014-010V and TP No 929015-010V to the alkali or acid connection (2).

- 1 Coupling
- 2 Alkali/Acid connections
- 3 Plastic hose
- 4 Pipe
- 5 Non-return valve
- 6 Threaded connection

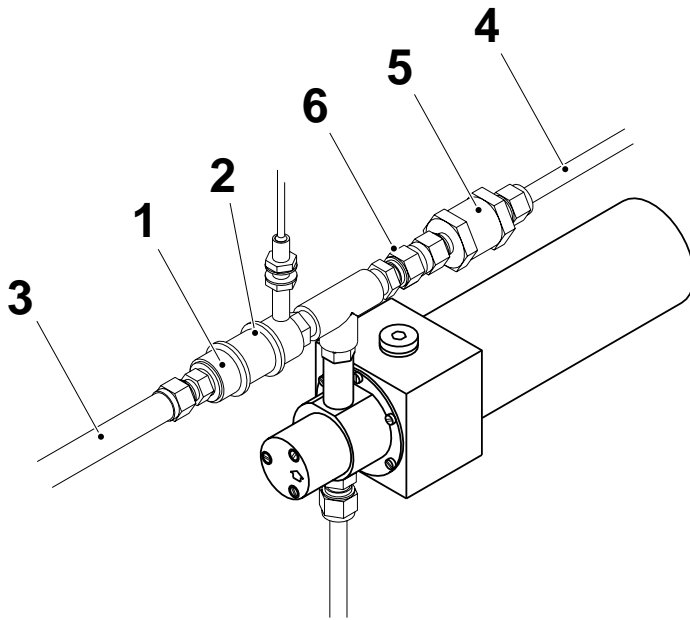

- 1 Coupling
- 2 Alkali/Acid connections
- 3 Plastic hose
- 4 Pipe
- 5 Non-return valve
- 6 Threaded connection

## 5

Connect the plastic hose (3) to the factory water circuit.

Open the water tap and let the water flow for almost 20 sec. (pressure range 1/2 bar; 15/30 psi) in order to clean the upper part of the concentrated circuit.

2.2TB17448en.fm

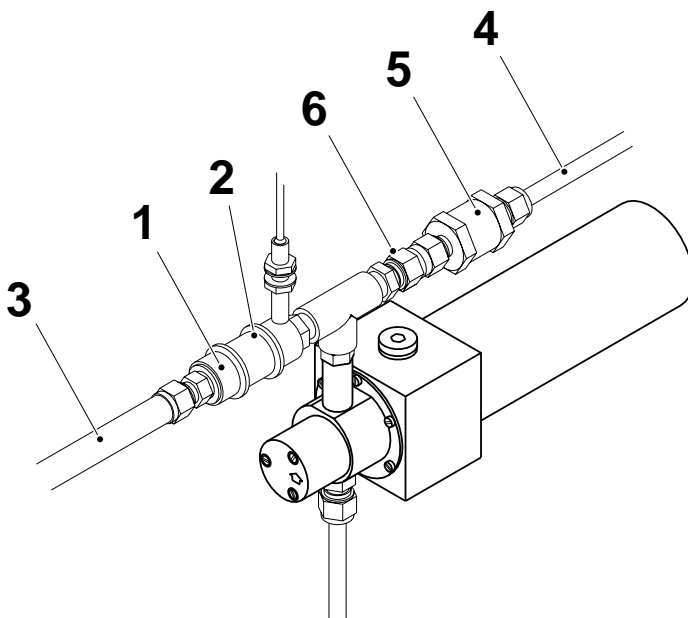

- 1 Coupling
- 2 Alkali/Acid connections
- 3 Plastic hose
- 4 Pipe
- 5 Non-return valve
- 6 Threaded connection

## 6

Close the water supply.

Remove the pipe (4), the non-return valve (5) and the threaded connection (6).

## 7

Fit the plug (7) on the T-connection (8).

Open the water supply in order to clean the pipe (9).

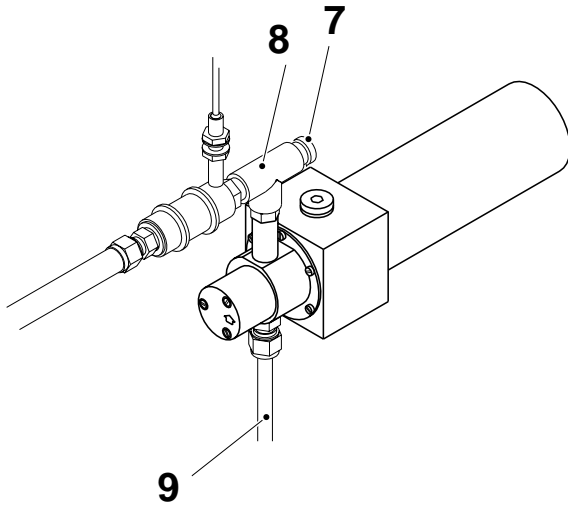

- 7 Plug
- 8 T-connection
- 9 Pipe

### Note!

Let the water flow for not more 5 sec. because in this phase water flows into the tank of chemical product with a dilution effect.

## 8

Disconnect the pipe (9) from the tank housing (10) and turn it out.

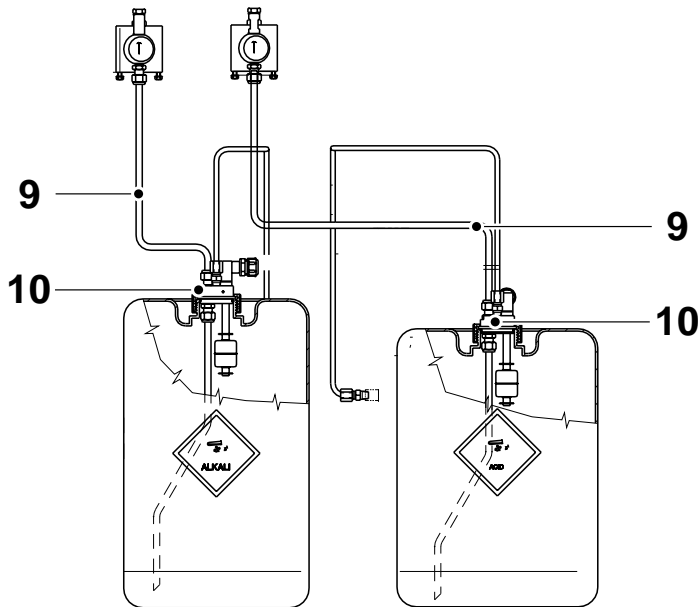

- 9 Pipe
- 10 Tank housing

### 9

Open the water supply and let the water flow for almost 20 sec. in order to obtain a complete cleaning of the lower part of the circuit.

---

### 10

Disconnect the quick release coupling.

This page intentionally left blank

2.2TB17448en.fm

# Technical data

## Setting

<b>Pressures</b>	<b>Unit</b>	<b>Value</b>
Input air	MPa	0.60 - 0.70
Input steam	MPa	0.30 - 0.40
Input water	MPa	0.30 - 0.40

<b>Electrical</b>	<b>Unit</b>	<b>Value</b>
Main fuse	A	16
Electrical connection	V	380
Electric frequency	Hz	50/60

2..2TB20448en.fm

This page intentionally left blank

2.2TB20448en.fm

This page is intentionally left blank

